



FUZE WASH Z120™

The FUZE WASH Z120™ is a single source par moving head luminaire with a 120W Quad Color RGBW COB LED. Features 7° to 55° motorized zoom, pan and tilt,

RGBW color mixing, electronic strobe and selectable dimming curve effects, DMX and RDM (remote device management) protocol support, DMX and power in/out connections, LCD menu display with 7 button control panel, multiple unit power linking, flicker free operation for TV and FILM, and a multi-voltage universal auto switching power supply (110-240v).



FEATURES

120W RGBW COB LED Moving Head Wash Luminaire

RGBW Color Mixing

7° TO 55° Wide Motorized Zoom Range

Variable Dimming Curves

Multiple Unit Power Linking

RDM (Remote Device Management)

Flicker Free Operation for TV and FILM

Optional Snoot Lens



ELATION | FUZE WASH Z120™ | Product Specification Sheet

Specifications are subject to change without notice ©Elation Professional 09/19/16

PRODUCT SPECIFICATIONS

SOURCE

120W RGBW COB LED
100,000 Hour Average LED Life*

*LED Life may vary depending on several factors including but not limited to: Environmental Conditions, Power/Voltage, Usage Patterns (On-Off Cycling), Control and Dimming.

PHOTOMETRIC DATA

10,640 LUX 988 FC @9.8' (3m) (7° Full ON)
692 LUX 64 FC @9.8' (3m) (55° Full ON)

EFFECTS

RGBW Color Mixing
7° - 55° Beam Zoom Range
Electronic Strobe and Dimming
Variable Dimming Curves
64 Color Presets and 14 Unique Color Macros

COLOR

RGBW

CONTROL / CONNECTIONS

4 DMX Channel Modes (19 Total Channels)
7 Button Control Panel and LCD Menu Display
RDM (Remote Device Management)
3pin/5pin DMX and powerCON In/Out

SIZE / WEIGHT

Length: 13.3" (338mm)
Width: 9.0" (229mm)
Vertical Height: 18.2" (466mm)
Weight: 22 lbs. (10 kg)

ELECTRICAL / THERMAL

AC 110-240V - 50/60Hz
157W Max Power Consumption
Multiple Unit Power Linking
5°F to 113°F (-15°C to 45°C)

INCLUDED ITEMS

powerCON Power Cable

APPROVALS / RATINGS



Optional Snoot Available



PHOTOMETRIC DATA

MIN ZOOM - 7° Beam Diameter

	3 m	9.8 ft	4 m	13.1 ft	5 m	16.4 ft
7° Beam Diameter	0.3	1.0	0.39	1.3	0.47	1.5
14° Field Diameter	0.98	3.2	1.28	4.2	1.58	5.2
	lux	fc	lux	fc	lux	fc
RED LEDs	1,828	170	1,210	112	790	73
GREEN LEDs	3,553	330	2,220	206	149	14
BLUE LEDs	940	87	569	53	390	36
WHITE LEDs	5,298	492	3,161	294	2,184	203
FULL ON	10,640	988	6,722	624	4,508	419

MAX ZOOM - 55° Beam Diameter

	3 m	9.8 ft	4 m	13.1 ft	5 m	16.4 ft
55° Beam Diameter	3.12	10.2	4.16	13.6	5.2	17.1
57° Field Diameter	3.16	10.4	4.2	13.8	5.24	17.2
	lux	fc	lux	fc	lux	fc
RED LEDs	127	12	83	8	50	5
GREEN LEDs	232	22	134	12	90	8
BLUE LEDs	58	5	36	3	25	2
WHITE LEDs	347	32	193	18	134	12
FULL ON	692	64	422	39	270	25

DIMENSIONAL DIAGRAMS

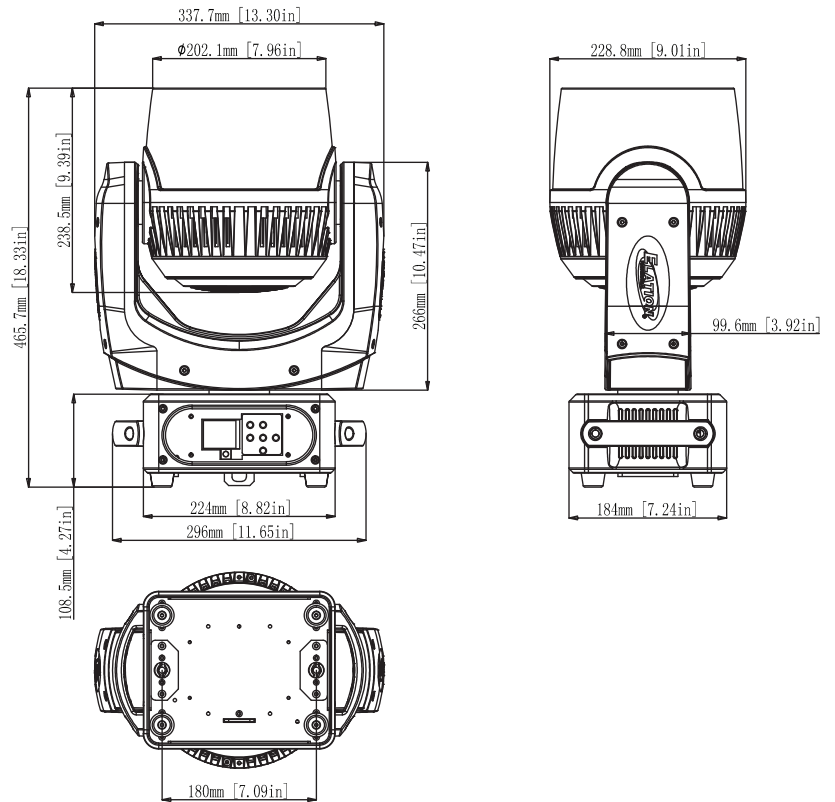

OPTIONAL ACCESSORIES

ORDER CODE	ITEM
FW120SNOOT	FUZE WASH Z120 Snoot
TRIGGER CLAMP	Heavy Duty Wrap Around Hook Style Clamp
AC3PDMX5PRO	5 ft. (1.5m) 3pin PRO DMX Cable (Additional cable lengths available)
AC5PDMX5PRO	5 ft. (1.5m) 5pin PRO DMX Cable (Additional cable lengths available)
PLC3	3 ft. (1m) PowerCON TRUE1 Power Link Cable
*** pending ***	Road Case for FUZE WASH Z120™