



FUZE PAR 175™

The FUZE PAR 175™ is a single source silent operating par with zoom featuring a 175W RGBW COB LED engine, 8° to 35° motorized zoom, an advanced cooling system, smooth RGBW color mixing, 64 color presets and 14 unique color macros, electronic strobe and 16-bit variable dimming curve modes, flicker free operation for TV and FILM, 3/5pin DMX and powerCON in/out connections, (4) button LCD control display panel, integrated dual rigging yokes, and a multi-voltage universal auto switching power supply (100-240v). Gel frame and barn doors included.



FEATURES

Single Source Silent Operating Par with Zoom

175W RGBW COB LED Engine

Advanced Cooling System

8° to 35° Motorized Zoom

Smooth RGBW Color Mixing

16-bit Variable Dimming Curve Modes

64 Color Presets and Color Macro Programs

RDM (Remote Device Management)

Flicker Free Operation for TV and FILM

Multiple Unit Power Linking

Gel Frame and Barn Doors Included



PRODUCT SPECIFICATIONS

SOURCE

175W RGBW COB LED
50,000 Hour Average LED Life*

*May vary depending on several factors including but not limited to:
Environmental Conditions, Power/Voltage, Usage Patterns (On-Off Cycling), Control and Dimming.

PHOTOMETRIC DATA

15,026 LUX 1396 FC LUX FC @6.6' (2m) (8° Full ON)
3,481 LUX 323 FC LUX FC @6.6' (2m) (35° Full ON)

EFFECTS

8° - 35° Motorized Zoom
64 Color Presets and Color Macro Programs
Electronic Strobe
16-bit Variable Dimming Curve Modes

COLOR

RGBW

CONTROL / CONNECTIONS

12 DMX Channel Modes (14 Total Channels)
4 Button Control Panel and LCD Menu Display
RDM (Remote Device Management)
5pin DMX and powerCON TRUE1 In/Out

SIZE / WEIGHT

Length: 18.2" (463mm)
Width: 16.2" (411mm)
Vertical Height: 17.0" (431mm)
Weight: 20.0 lbs. (9.07kg)

ELECTRICAL / THERMAL

AC 100-240V - 50/60Hz
200W Max Power Consumption
Multiple Unit Power Linking
5°F to 113°F (-15°C to 45°C)

INCLUDED ITEMS

Gel Frame
Barn Doors
powerCON Power Cable

APPROVALS / RATINGS



PHOTOMETRIC DATA

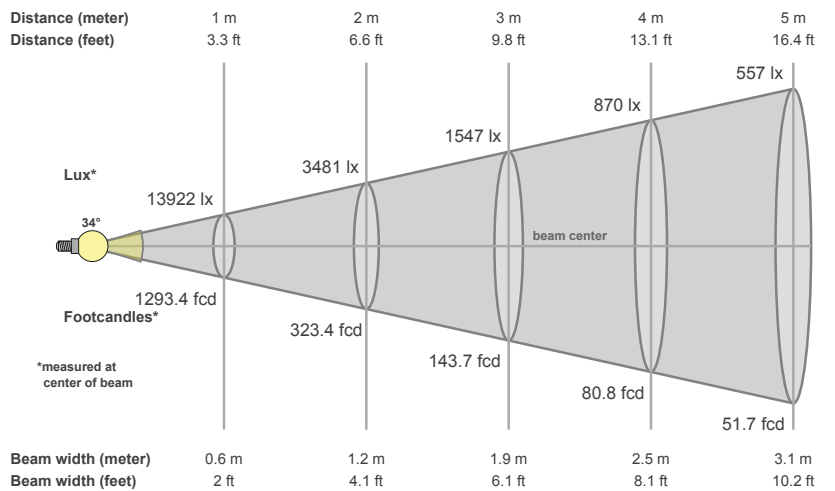
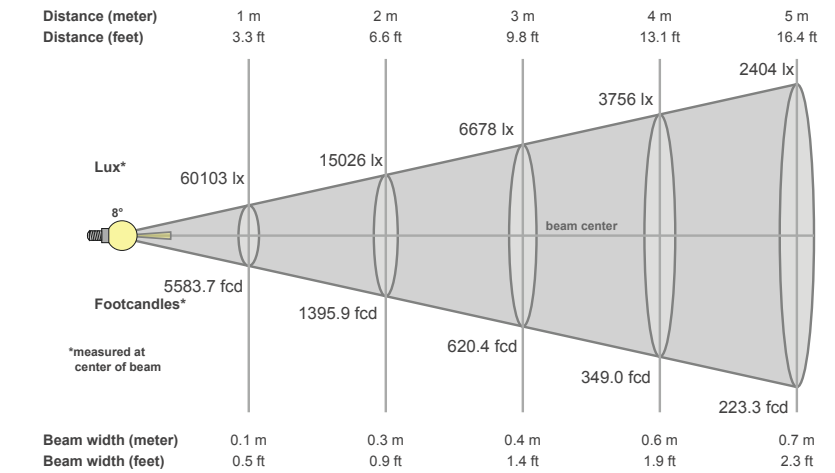

DIMENSIONAL DIAGRAMS

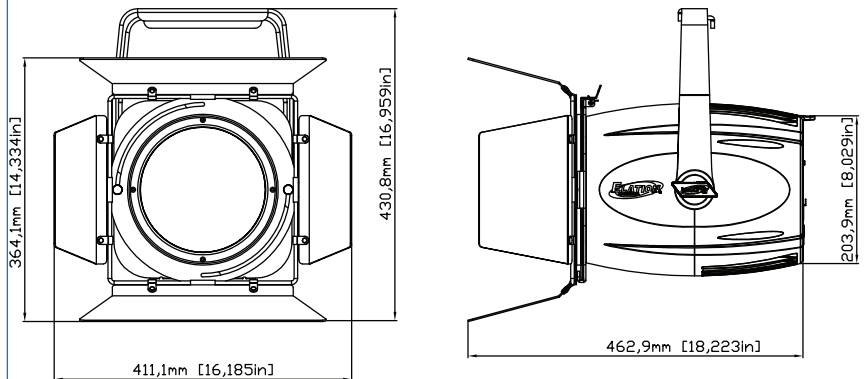

ORDERING INFORMATION

FUZ761	FUZE WASH 575
TRIGGER CLAMP	Heavy Duty Wrap Around Hook Style Clamp
SCABLE60	24" (610mm) 60 lbs. (27 kg) Rated Safety Cable
AC3PDMX5PRO	5 ft. (1.5m) 3pin PRO DMX Cable (Additional cable lengths available)
AC5PDMX5PRO	5 ft. (1.5m) 5pin PRO DMX Cable (Additional cable lengths available)
PLC2	2 ft. powerCON Link Cable Link Cable