

## FUZE WASH Z350™

The FUZE WASH Z350™ is a single source par moving head luminaire with a 350W Quad Color RGBW COB LED. Features 6° to 46° motorized zoom, pan and tilt, RGBW color mixing, electronic strobe and selectable dimming curve effects, DMX and RDM (remote device management) protocol support, DMX and power in/out connections, LCD menu display with 7 button control panel, multiple unit power linking, flicker free operation for TV and FILM, and a multi-voltage universal auto switching power supply (110-240v).



### FEATURES

**350W RGBW COB LED Moving Head Wash Luminaire**

**RGBW Color Mixing**

**6° to 46° Motorized Zoom Range**

**Variable Dimming Curves**

**Multiple Unit Power Linking**

**RDM (Remote Device Management)**

**Flicker Free Operation for TV and FILM**

**Optional Snoot Lens**



**PRODUCT SPECIFICATIONS**

**SOURCE**

350W RGBW COB LED  
100,000 Hour Average LED Life\*

\*May vary depending on several factors including but not limited to:  
Environmental Conditions, Power/Voltage, Usage Patterns (On-Off Cycling), Control and Dimming.

**PHOTOMETRIC DATA**

60,280 LUX 5,600 FC @6.6' (2m) (6° Full ON)  
3,735 LUX 347 FC @6.6' (2m) (46° Full ON)

**EFFECTS**

RGBW Color Mixing  
6° - 46° Beam Zoom Range  
Electronic Strobe and Variable Dimming Curves  
64 Color Presets and 14 Unique Color Macros

**COLOR**

RGBW

**CONTROL / CONNECTIONS**

4 DMX Channel Modes (19 Total Channels)  
7 Button Control Panel and LCD Menu Display  
RDM (Remote Device Management)  
3pin/5pin DMX and powerCON In/Out

**SIZE / WEIGHT**

Length: 16.3" (414mm)  
Width: 11.6" (294mm)  
Vertical Height: 18.0" (461mm)  
Weight: 43 lbs. (19.5 kg)

**ELECTRICAL / THERMAL**

AC 110-240V - 50/60Hz  
399W Max Power Consumption  
Multiple Unit Power Linking  
5°F to 113°F (-15°C to 45°C)

**INCLUDED ITEMS**

Omega Brackets  
powerCON Power Cable

**APPROVALS / RATINGS**



Optional Snoot Available



Specifications are subject to change without notice ©Elation Professional 04/19/17

**PHOTOMETRIC DATA**

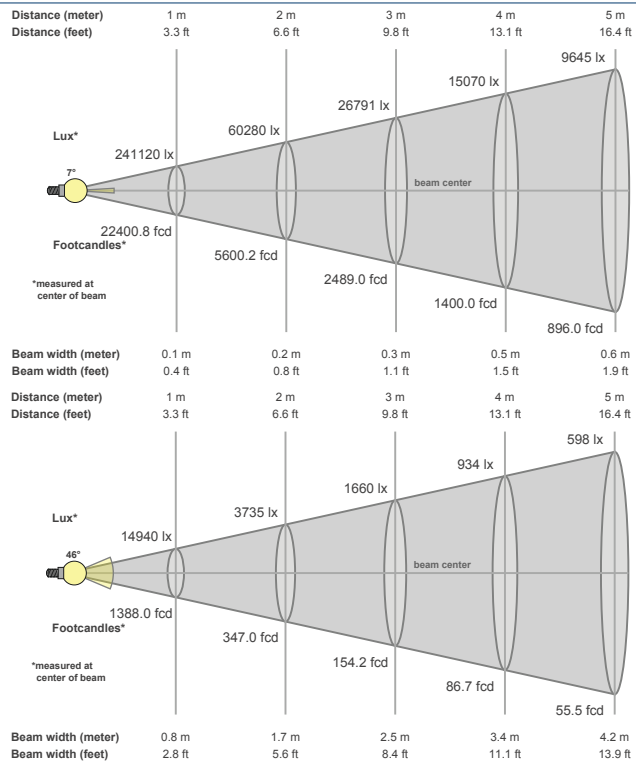

**DIMENSIONAL DIAGRAMS**

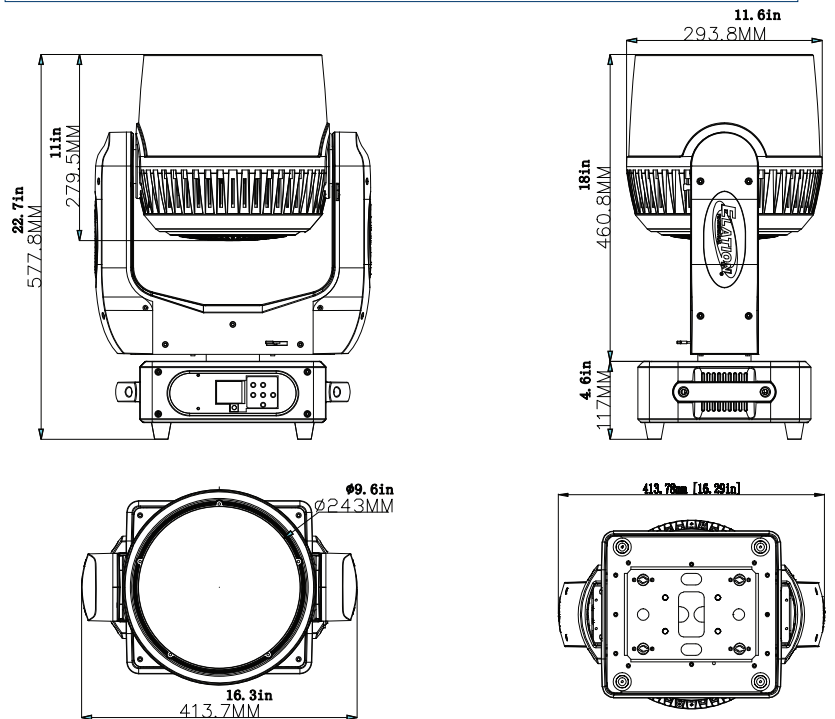

**OPTIONAL ACCESSORIES**

ORDER CODE	ITEM
FW350SNOOT	FUZE WASH Z350 Snoot
TRIGGER CLAMP	Heavy Duty Wrap Around Hook Style Clamp
AC3PDMX5PRO	5 ft. (1.5m) 3pin PRO DMX Cable (Additional cable lengths available)
AC5PDMX5PRO	5 ft. (1.5m) 5pin PRO DMX Cable (Additional cable lengths available)
PLC3	3 ft. (1m) PowerCON TRUE1 Power Link Cable
DRC350FUZE	Quad Road Case for FUZE WASH Z350