



## SIXPAR 200™

The new indoor version SIXPAR 200™ features (12) 12W 6-IN-1 RGBAW+UV LEDs, 100,000 average hour LED life, 15° beam and 25° field angles, electronic strobe and dimming (0-100%), 5 variable dimming curve modes, dual yoke / floor stand, multiple unit power linking, RDM (remote device management), rugged die-cast aluminum exterior, flicker free operation for TV and FILM, 150W max power consumption, and a multi-voltage universal auto switching power supply (110-250v).

### FEATURES

- Indoor Par Up Light**
- (12) 12W 6-in-1 RGBAW+UV LEDs**
- 100,000 Average Hour LED Life**
- 15° Beam and 25° Field Angles**
- 5 Variable Dimming Curve Modes**
- Dual Yoke / Floor Stand**
- Multiple Unit Power Linking**
- RDM - Remote Device Management**
- Rugged Die-Cast Aluminum Exterior**
- Flicker Free Operation for TV and FILM**



ELATION | SIXPAR 200™ | Product Specification Sheet

Specifications are subject to change without notice ©Elation Professional 06/08/16

**PRODUCT SPECIFICATIONS**

**FEATURES**

- 15° Beam 25° Field Angles
- 5 Variable Dimming Curve Modes
- Dual Yoke / Floor Stand
- Multiple Unit Power Linking
- RDM - Remote Device Management
- Rugged Die-Cast Aluminum Exterior
- Flicker Free Operation for TV and FILM

**SOURCE**

- (12) 12W 6-in-1 RGBAW+UV LEDs
- 100,000 Hour Average LED Life

**PHOTOMETRIC DATA**

- 22,250 LUX 2.067 FC @3.3' (1m) (15° Full ON)
- 5,600 LUX 520 FC @6.6' (2m) (15° Full ON)
- 2,500 LUX 232 FC @9.8' (3m) (15° Full ON)
- 1,360 LUX 126 FC @13.1' (4m) (15° Full ON)
- 930 LUX 86 FC @16.5' (5m) (15° Full ON)

**EFFECTS**

- Electronic Strobe
- Color and Chase Macros
- Electronic Dimming: 0% - 100%
- 5 Variable Dimming Curve Modes

**CONTROL / CONNECTIONS**

- (4) DMX Channel Modes (6 / 7 / 8 / 12)
- (4) Button Touch Control Panel
- LCD Menu Display
- 3pin & 5pin DMX and powerCON In/Out

**SIZE / WEIGHT**

- Length: 12.3" (313mm)
- Width: 4.9" (125mm)
- Vertical Height: 11.8" (300mm)
- Weight: 12.6 lbs. (5.7 kg)

**ELECTRICAL / THERMAL**

- AC 110-250V - 50/60Hz
- 150W Max Power Consumption
- Power Linking: 8pcs @110V / 18pcs @240V
- 5°F to 113°F (-15°C to 45°C)

**APPROVALS / RATINGS**

IP20



**INSTALLATION**

- Rigging: Integrated Dual Yoke / Floor Stand
- Working Position: Any (360°)

**INCLUDED ITEMS**

- powerCON Power Cable



Gel Frame Holder + Barn Door

**PHOTOMETRIC DATA**

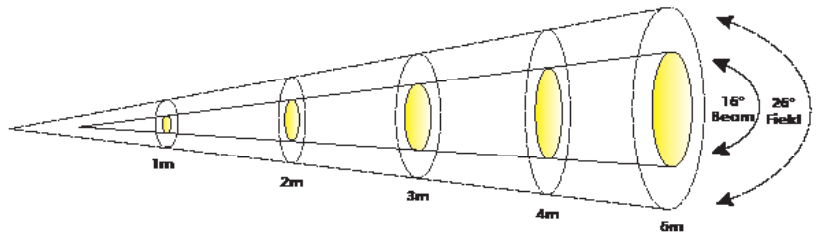

Distance	m		ft		m		ft		m		ft	
	1	3.3	2	6.6	3	9.8	4	13.1	5	16.4		
16° Beam Diameter	0.4	1.3	0.64	2.1	0.85	2.8	1.05	3.4	1.32	4.3		
26° Field Diameter	0.45	1.5	0.88	2.9	1.33	4.4	1.77	5.8	2.21	7.3		
	lux	fc	lux	fc	lux	fc	lux	fc	lux	fc		
RED LEDs	3.360	314	862	80	386	36	195	18	126	12		
GREEN LEDs	5.360	498	1.392	129	632	59	334	31	221	21		
BLUE LEDs	6.710	623	1.755	163	804	75	436	41	288	27		
WHITE LEDs	5.830	542	1.535	143	704	65	375	35	247	23		
AMBER LEDs	2.470	229	645	60	294	27	162	15	102	9		
UV LEDs	1.177	109	308	29	138	13	78	7	49	5		
FULL ON	22.250	2.067	5.600	520	2.500	232	1.360	126	930	86		

**DIMENSIONAL DIAGRAMS**

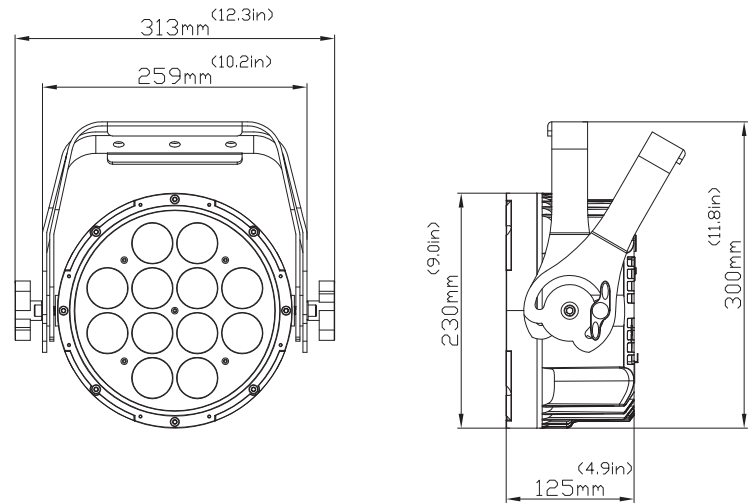

**OPTIONAL ACCESSORIES**

ORDER CODE	ITEM
TRIGGER CLAMP	Heavy Duty Wrap Around Hook Style Clamp
SIXPAR200/GFH	Gel Frame and Holder Kit
SIXPAR/BD200	Barn Door (Gel Frame Holder Kit Required - Not Included)
LSF536	Light Shaping Filter 30° 20" x 24" Sheet
LSF537	Light Shaping Filter 20° 20" x 22" Sheet
LSF538	Light Shaping Filter 60° x 1° 20" x 24" Sheet
LSF559	Light Shaping Filter 10° 20" x 24" Sheet
EWDMXSYSTEM	Wireless DMX System (1 Transmitter, 1 Receiver)
EWDMXT	Wireless DMX Transmitter
EWDMXR	Wireless DMX Receiver
PLC3	3' (1m) PowerCON PRO Link Cable
AC3PDMX5PRO	5 ft. (1.5m) 3pin PRO DMX Cable
AC5PDMX5PRO	5 ft. (1.5m) 5pin PRO DMX Cable
	Additional Cable Lengths Available

Specifications are subject to change without notice ©Elation Professional 06/08/16