

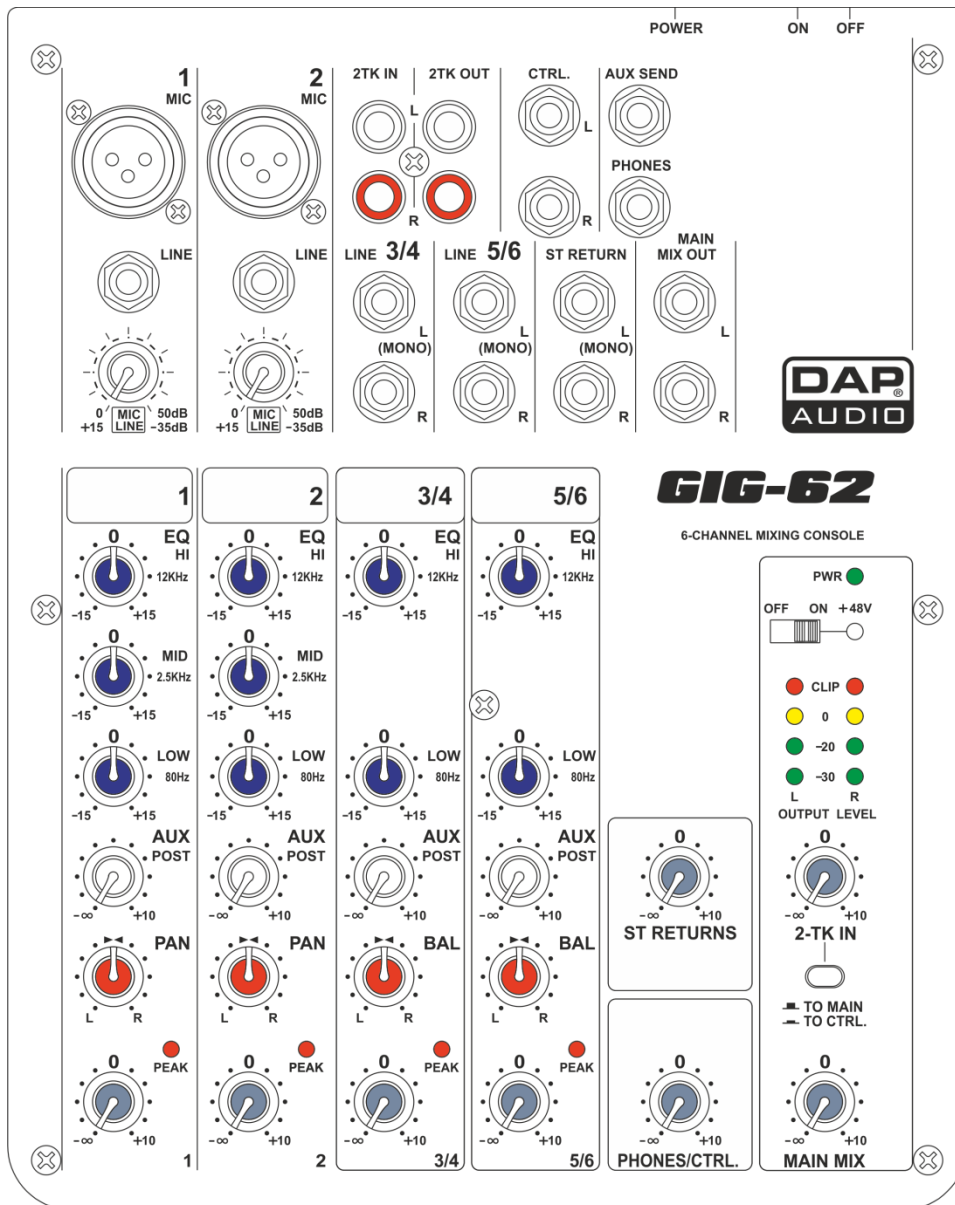

MANUAL



ENGLISH

GIG-62
Order code: D2281

Table of contents

Warning	2
Unpacking Instructions.....	2
Safety Instructions	2
Operating Determinations	4
Return Procedure.....	4
Claims.....	4
Description of the device	5
Features	5
Overview	5
Installation	6
Introduction.....	6
Ready to start	6
Control Elements	7
Installation and connection	10
Connection Cables	11
Block Diagram	12
Technical Specifications	13
Dimensions	14

Warning



**FOR YOUR OWN SAFETY, PLEASE READ THIS USER MANUAL CAREFULLY
BEFORE YOUR INITIAL START-UP!**



Unpacking Instructions

Immediately upon receiving this product, carefully unpack the carton and check the contents to ensure that all parts are present and have been received in good condition. Notify the dealer immediately and retain packing material for inspection if any parts appear damaged from shipping or the carton itself shows signs of mishandling. Save the carton and all packing materials. In the event that a fixture must be returned to the factory, it is important that the fixture be returned in the original factory box and packing.

Your shipment includes:

- GIG-62 mixing console
- AC power adapter
- User Manual



CAUTION!
Keep this device away from rain and moisture!
Unplug mains lead before opening the housing!



Safety Instructions

Every person involved with the installation, operation and maintenance of this system has to:

- be qualified
- follow the instructions of this manual



CAUTION! Be careful with your operations.
With a dangerous voltage you can suffer
a dangerous electric shock when touching the wires!



Before you initial start-up, please make sure that there is no damage caused by transportation. Should there be any, consult your dealer and do not use the system.

To maintain perfect condition and to ensure a safe operation, it is absolutely necessary for the user to follow the safety instructions and warning notes written in this manual.

Please consider that damages caused by manual modifications to the system are not subject to warranty.

This system contains no user-serviceable parts. Refer servicing to qualified technicians only.

IMPORTANT:

The manufacturer will not accept liability for any resulting damages caused by the non-observance of this manual or any unauthorized modification to the system.

- Never let the power-cord come into contact with other cables! Handle the power-cord and all connections with the mains with particular caution!
- Never remove warning or informative labels from the unit.

- Never use anything to cover the ground contact.
- Never leave any cables lying around.
- Do not insert objects into air vents.
- Do not connect this system to a dimmer pack.
- Do not switch the system on and off in short intervals, as this would reduce the system's life.
- Do not open the device and do not modify the device.
- Do not drive the inputs with a signal level bigger, than required to drive the equipment to full output.
- Do not plug Mics into the console (or stage box) while Phantom Power is on. Also mute the monitor / Pa system when turning Phantom Power on or off. Allow the system to adjust for a couple of seconds, before setting the input gains.
- Only use system indoor, avoid contact with water or other liquids.
- Avoid flames and do not put close to flammable liquids or gases.
- Always disconnect power from the mains, when system is not used. Only handle the power-cord by the plug. Never pull out the plug by tugging the power-cord.
- Always operate the unit with the AC ground wire connected to the electrical system ground.
- Make sure you don't use the wrong kind of cables or defective cables.
- Make sure that the signals into the mixer are balanced, otherwise hum could be created.
- Make sure you use DI boxes to balance unbalanced signals; All incoming signals should be clear.
- Make sure that the available voltage is not higher than stated on the rear panel.
- Make sure that the power-cord is never crimped or damaged. Check the system and the power-cord from time to time.
- Please turn off the power switch, when changing the power cord or signal cable, or select the input mode switch.
- Extreme frequency boosts in connection with a high input signal level may lead to overdriving your equipment. Should this occur, it is necessary to reduce the input signal level by using the INPUT control.
- To emphasize a frequency range, you don't necessarily have to move its respective control upward; try lowering surrounding frequency ranges instead. This way, you avoid causing the next piece of equipment in your sound path to overdrive. You also preserve valuable dynamic reserve ("headroom")
- Avoid ground loops! Always be sure to connect the power amps and the mixing console to the same electrical circuit to ensure the same phase!
- If system is dropped or struck, disconnect mains power supply immediately. Have a qualified engineer inspect for safety before operating.
- If the system has been exposed to drastic temperature fluctuation (e.g. after transportation), do not switch it on immediately. The arising condensation water might damage your system. Leave the system switched off until it has reached room temperature.
- If your Dap Audio device fails to work properly, discontinue use immediately. Pack the unit securely (preferably in the original packing material) and return it to your Dap Audio dealer for service.
- Repairs, servicing and electric connection must be carried out by a qualified technician.
- For replacement use fuses of same type and rating only.
- WARRANTY: Till one year after date of purchase.



Disposing of this product should not be placed in municipal waste and should be separate collection.

Operating Determinations

- This device is not designed for permanent operation. Consistent operation breaks will ensure that the device will serve you for a long time without defects.
- The minimum distance between light-output and the illuminated surface must be more than 0.5 meter.
- The maximum ambient temperature $t_a = 45^\circ\text{C}$ must never be exceeded.
- The relative humidity must not exceed 50 % with an ambient temperature of 35°C .
- If this device is operated in any other way, than the one described in this manual, the product may suffer damages and the warranty becomes void.
- Any other operation may lead to dangers like short-circuit, burns, electric shock, crash, etc.

You endanger your own safety and the safety of others!



Return Procedure



Returned merchandise must be sent prepaid and in the original packing, call tags will not be issued. Package must be clearly labeled with a Return Authorization Number (RMA number). Products returned without an RMA number will be refused. Highlite will not accept the returned goods or any responsibility. Call Highlite 0031-455667723 or mail aftersales@highlite.nl and request an RMA prior to shipping the fixture. Be prepared to provide the model number, serial number and a brief description of the cause for the return. Be sure to properly pack fixture, any shipping damage resulting from inadequate packaging is the customer's responsibility. Highlite reserves the right to use its own discretion to repair or replace product(s). As a suggestion, proper UPS packing or double-boxing is always a safe method to use.

Note: If you are given an RMA number, please include the following information on a piece of paper inside the box:

- 1) Your name
- 2) Your address
- 3) Your phone number
- 4) A brief description of the symptoms

Claims

The client has the obligation to check the delivered goods immediately upon delivery for any shortcomings and/or visible defects, or perform this check after our announcement that the goods are at their disposal. Damage incurred in shipping is the responsibility of the shipper; therefore the damage must be reported to the carrier upon receipt of merchandise.

It is the customer's responsibility to notify and submit claims with the shipper in the event that a fixture is damaged due to shipping. Transportation damage has to be reported to us within one day after receipt of the delivery.

Any return shipment has to be made post-paid at all times. Return shipments must be accompanied with a letter defining the reason for return shipment. Non-prepaid return shipments will be refused, unless otherwise agreed in writing.

Complaints against us must be made known in writing or by fax within 10 working days after receipt of the invoice. After this period complaints will not be handled anymore.

Complaints will only then be considered if the client has so far complied with all parts of the agreement, regardless of the agreement of which the obligation is resulting.

Description of the device

Features

- Ultra-low noise discrete MIC Preamps with +48V Phantom Power.
- Extremely high headroom offering more dynamic range.
- 2 MIC Input Channels with XLR and balanced Line Input.
- 2 Stereo Input Channels with balanced TRS Jack.
- 3-band EQ and Peak LED on each MONO channel.
- 2-band EQ and Peak LED on STEREO channels.
- 1 AUX Send per channel for external effects and monitoring.
- 2-Track Input assignable to Main Mix or Control Room/Headphone Outputs.
- Balanced TRS output, Control Room and Headphone Outputs.

Overview

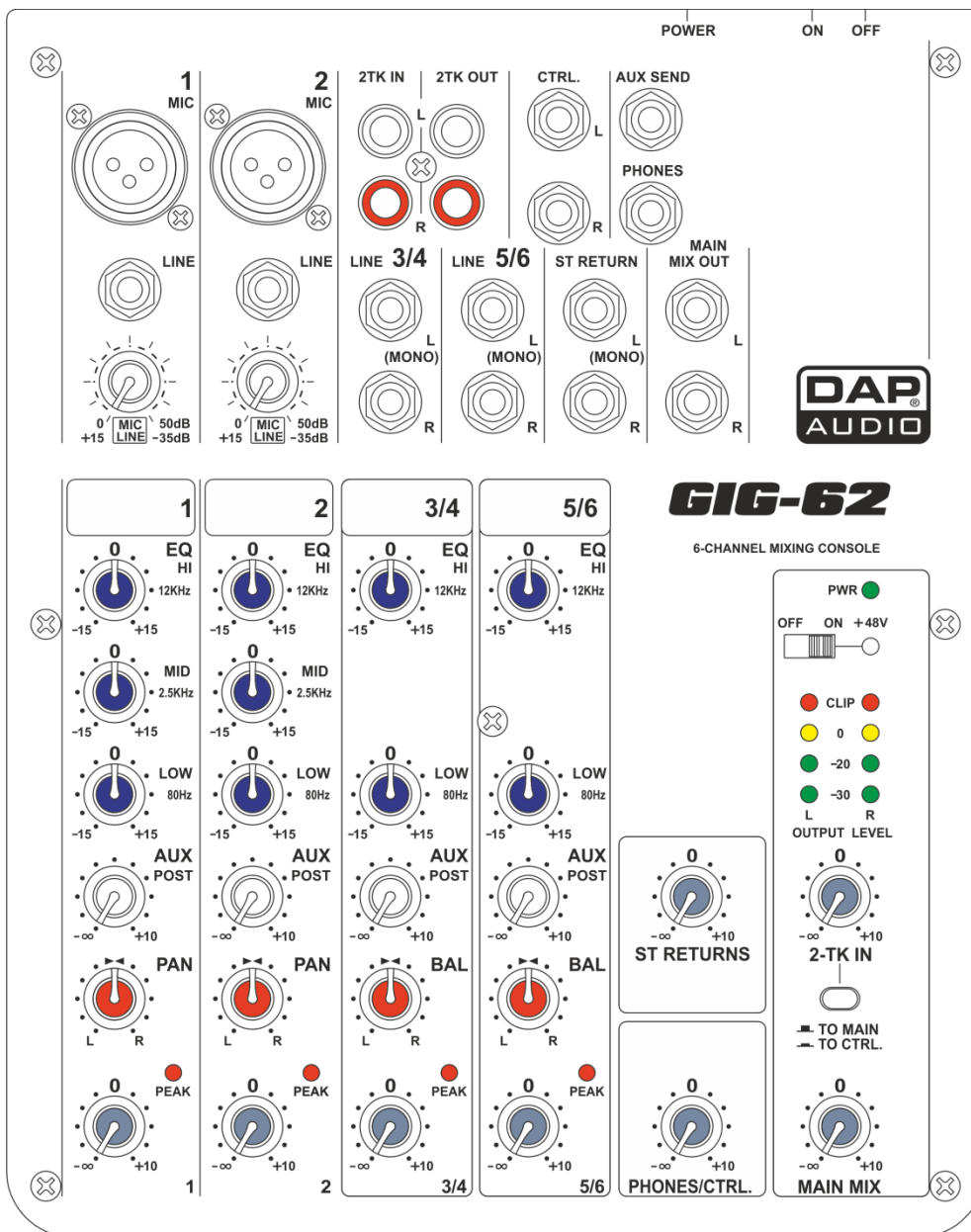

Installation

Introduction

This is a professional compact mixer that gives you great quality and better reliability than ever before. You will get the smooth, accurate more natural and open sound from this apparatus. It is really ideal for gigs, recording and fixed PA installations.

The GIG-62 Mixing Console is packed with features that cannot be found in other consoles of its size: 2 mono (provided with ultra-low noise microphone pre amplifiers and Phantom Power at +48 Volt) and 2 stereo input channels, each of them provided with a 3-band equalizer for HI, MID and LOW control, as well as 1 auxiliary control, highly accurate 4-segment bar graph meter and 2-track input assignable to main mix, control room/phones Outputs etc.

This unit is very easy to operate, but we advise you to go through each section of this manual carefully.

Ready to start

- 1) Please check the AC voltage available in your country before connecting your mixer to the AC socket.
- 2) Be sure that the main power switch is turned off before connecting the mixer to the AC socket. You should also make sure that all input and output controls are turned down. This will avoid damage to your speakers and avoid excessive noise.
- 3) Always turn on the mixer before you turn on the power amplifier; turn off the mixer after the power amplifier is turned off.
- 4) Before connecting and disconnecting the unit from the power source, always turn off the unit.
- 5) Cleaning: Disconnect the mains power supply and then wipe the mixer with a damp cloth. Do not immerse in liquid. Do not use alcohol or solvents.

Control Elements

1. MIC INPUT JACKS (CHs 1,2)

The balanced XLR input connects to microphones, DI boxes and multicores.

2. LINE INPUT JACKS (CHs 1,2)

This is a 1/4" jack connector which connects to line-level signal sources (for example, keyboards, CD players and wireless microphone receivers). The input is balanced (TRS connector) but can also be used with unbalanced connectors (TS connector).

3. LINE INPUT JACKS (CHs 3/4 to 5/6)

The stereo channels consist of two line inputs (1/4" jacks), one for the left and one for the right channel. The inputs are unbalanced (TRS connectors). These channels can also be used as mono channels by connecting to the jack labeled "L" (left).

4. GAIN CONTROL

The GAIN CONTROL adjusts the input gain.

Be sure to set this control fully counter-clockwise before you connect or disconnect a signal source to or from one of the inputs.

MONO: The first value range between 0 and +50 refers to the microphone input, indicating the degree of amplification applied to the input's signal. The second value range between -35 and +15 dB refers to the amplification of the line input.

STEREO: The first value range between 0 and +40 refers to the microphone input, indicating the degree of amplification applied to the input's signal. The second value range between -20 and +20 dB refers to the amplification of the line input.

5. EQUALIZER

Hi

The high-frequency range is processed with a shelving filter above 12 kHz. You can boost or cut the bands up to 15 dB. When in center position (0 dB), the equalizer has a flat response.

MID

The HIGH MID control adjusts the mid frequency range. This is a peak filter which boosts and cuts the frequencies centered at 2,5 kHz. You can boost or cut the bands up to 15 dB. When in center position (0 dB), the equalizer has a flat response.

Low

The low-frequency range is processed with a shelving filter below 80 Hz. You can boost or cut the bands up to 15 dB. When in center position (0 dB), the equalizer has a flat response.

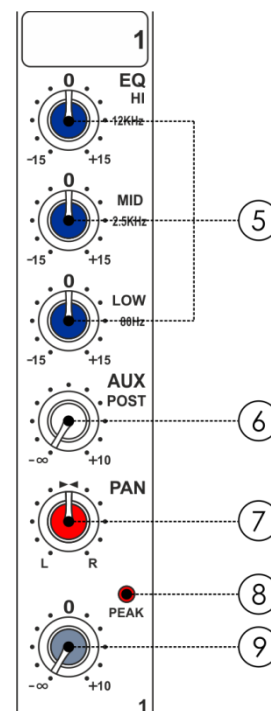
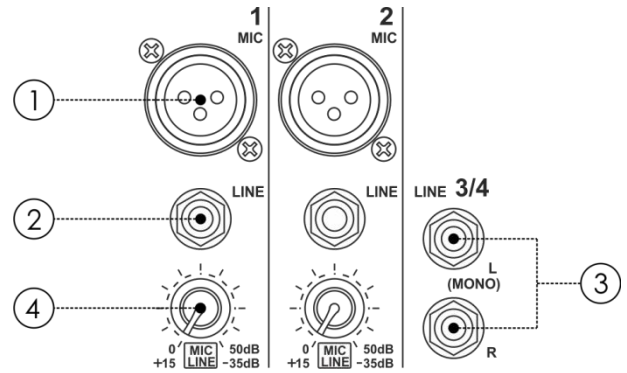

6. AUX/POST

The aux bus is used as additional, flexible send paths for various applications. The AUX control adjusts the volume level of the channel signal in the aux bus. The signal is tapped after the channel fader and therefore is affected by the position of the channel fader.

7. PAN/BAL CONTROL.

The PAN control determines the position of the channel signal in the stereo mix to which the channel signal is routed.

8. PEAK LED

The PEAK LED lights up as soon as the channel's level is too high. In this case, reduce the channel's input amplification with the GAIN control. The Peak LED lights at a level of 3 dB below clipping.

9. LEVEL

The LEVEL control adjusts the level of the channel signal as part of the main mix.

10. MAIN MIX

Use this control to adjust the output level of the main mix.

11. PHONES/CTRL-ROOM

The PHONES/CONTROL ROOM control adjusts the volume level of all solo signals routed to the headphone and the CONTROL ROOM outputs.

12. 2-TRACK SIGNAL PATH

If you push down the 2 TRACK SIGNAL PATH switch, the 2 TRACK IN signal will be routed to the CONTROL ROOM output. Push the switch again, the 2TRACK IN signal will be routed into the MAIN MIX output.

13. 2-TK IN

This control allows you to adjust the level of the 2-tk in.

14. OUTPUT LEVEL

This stereo 4 segments LED meter will indicate the level of the overall output signal.

15. ST RETURNS

This control adjusts the ST RETURN signal to the MAIN MIX output.

16. PHANTOM POWER ON/OFF SWITCH

Phantom power is used for operating a capacitor microphone. As a rule, dynamic microphones can still be used with phantom power, provided they are wired in a balanced configuration.

17. PHANTOM LED

This LED indicates when the phantom power is switched on for the microphone inputs.

18. PWR LED

This LED indicates when the power is switched on.

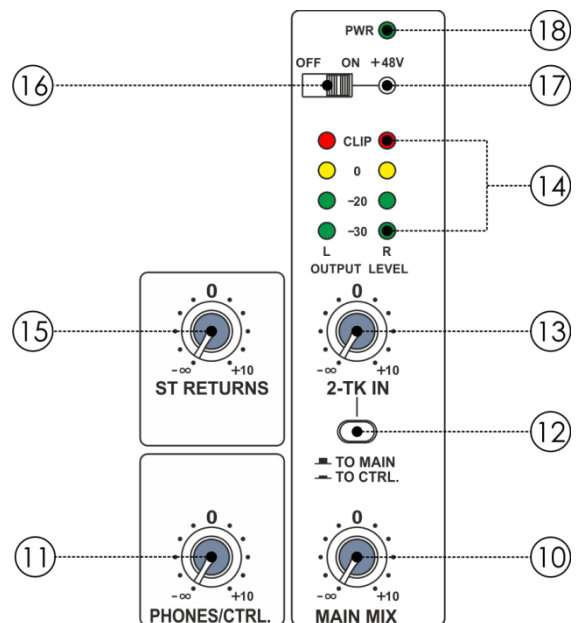

19. 2TK IN/OUT

TAPE IN

The CD/TAPE input connectors are used to hook up CD players, tape decks or other line-level sources.

TAPE OUT

The CD/TAPE output connectors provide the stereo main mix signal to a tape deck or DAT recorder to record your mix.

20. CONTROL ROOM OUTPUT

The CTRL-ROOM outputs will be used to send the signal to studio monitor speakers.

21. AUX SEND

The AUX SEND output provides the signal of the AUX bus.

22. PHONES

The PHONES output lets you plug in your headphones.

23. ST RETURNS

The ST RETURNS inputs L and R let you connect the mixer to additional equipment (players, effects processors, submixers, etc.).

24. MAIN MIX output

The MAIN MIX outputs are 1/4" TRS sockets and provide the main mix signal.

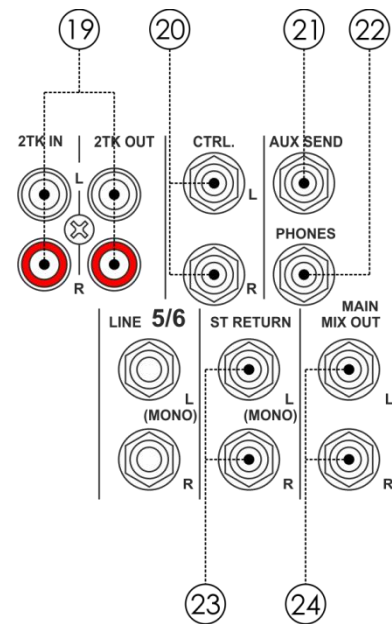

25. AC ADAPTER IN

This connector is used to connect the supplied AC adapter.

26. POWER ON/OFF

Use the POWER switch to turn on the mixing console. The POWER switch should always be in the "Off" position when you are about to connect your unit to the mains.

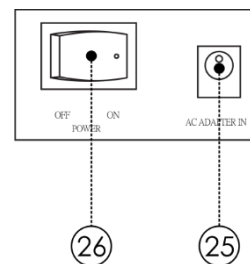

Installation and connection

At this point you are in a position to successfully operate your GIG-62 Mixing Console. However, we advise you to carefully read the following section to be a real master of your own mixer. Not paying enough attention to the input signal level, to the routing of the signal and the assignment of the signal will result in unwanted distortion, a corrupted signal or no sound at all. So you should follow these procedures for every single channel:

- Before connecting mics or instruments, make sure that the power of all your system components, including the mixer, are turned off. Also, make sure that all the input and output controls are turned down. This will avoid damage to your speakers and avoid excessive noise.
- Properly connect all external devices such as mics, power amplifiers, speakers, effect processor etc.
- Now, turn on the power of any peripheral devices, then power up the mixer.
- Set the output level of your mixer or the connected power amplifier at no more than 75%.
- Set the CONTROL ROOM/PHONE level at no more than 50%.
- Position HI, MID and LOW EQ controls on middle position.
- Position panoramic (PAN/BAL) control on center position.
- While speaking into the mic (or playing the instrument), adjust the channel Level control so that the PEAK LED will blink occasionally, in this way you will maintain good headroom and dynamic range.
- You can shape the tone of each channel by adjusting the equalizer controls as desired.
- Now repeat the same sequence for all the input channels. The main LEDs can move up into the red section, in this case you can adjust the overall output level through the MAIN MIX control.

Connection Cables

Take care of your cables, always holding them by the connectors and avoiding knots and twists when coiling them: This gives the advantage of increasing their life and reliability. Periodically check your cables. A great number of problems (faulty contacts, ground hum, discharges, etc.) are caused entirely by using unsuitable or faulty cables.

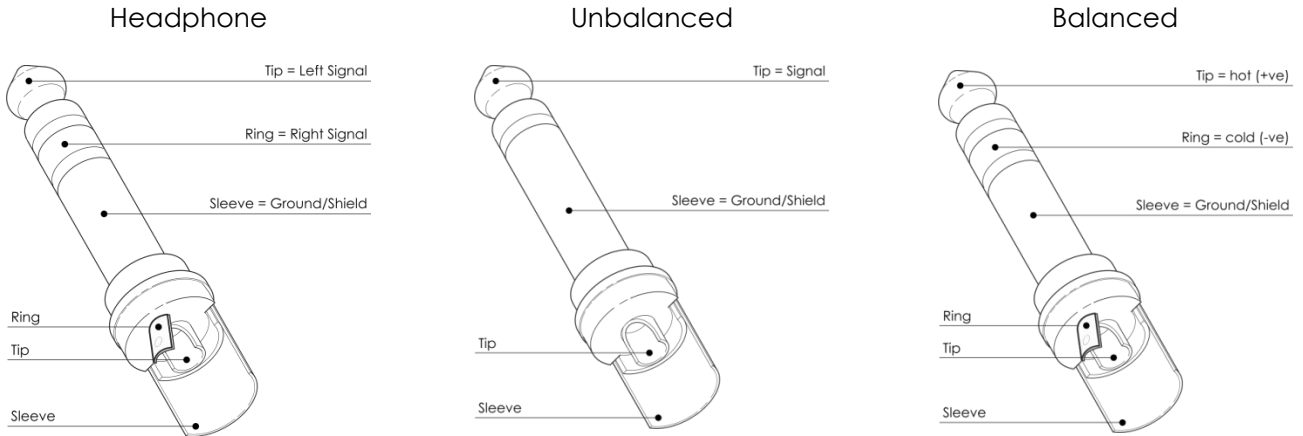

For these applications the unit provides 1/4" TRS and XLR connectors to easily interface with most professional audio devices. Follow the configuration examples below for your particular connection.

Unbalanced



Balanced

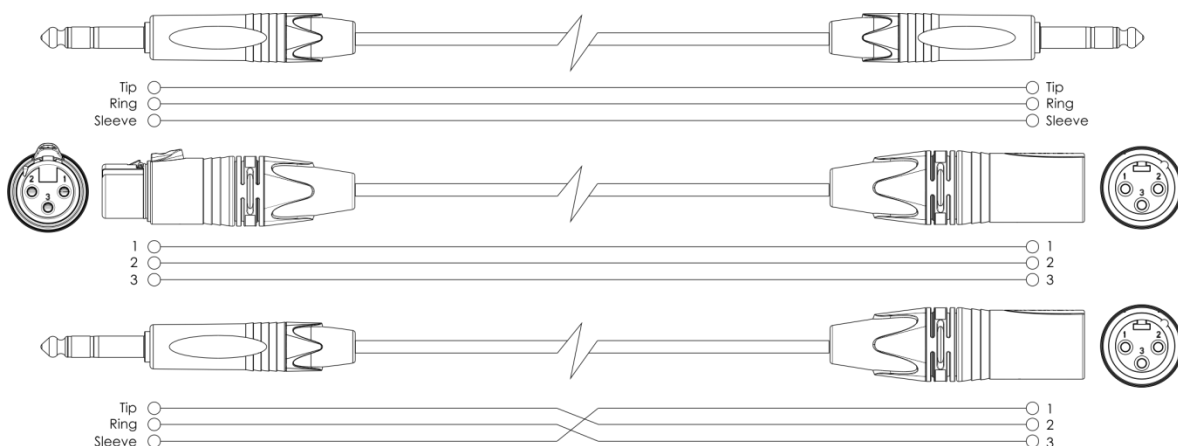

Block Diagram

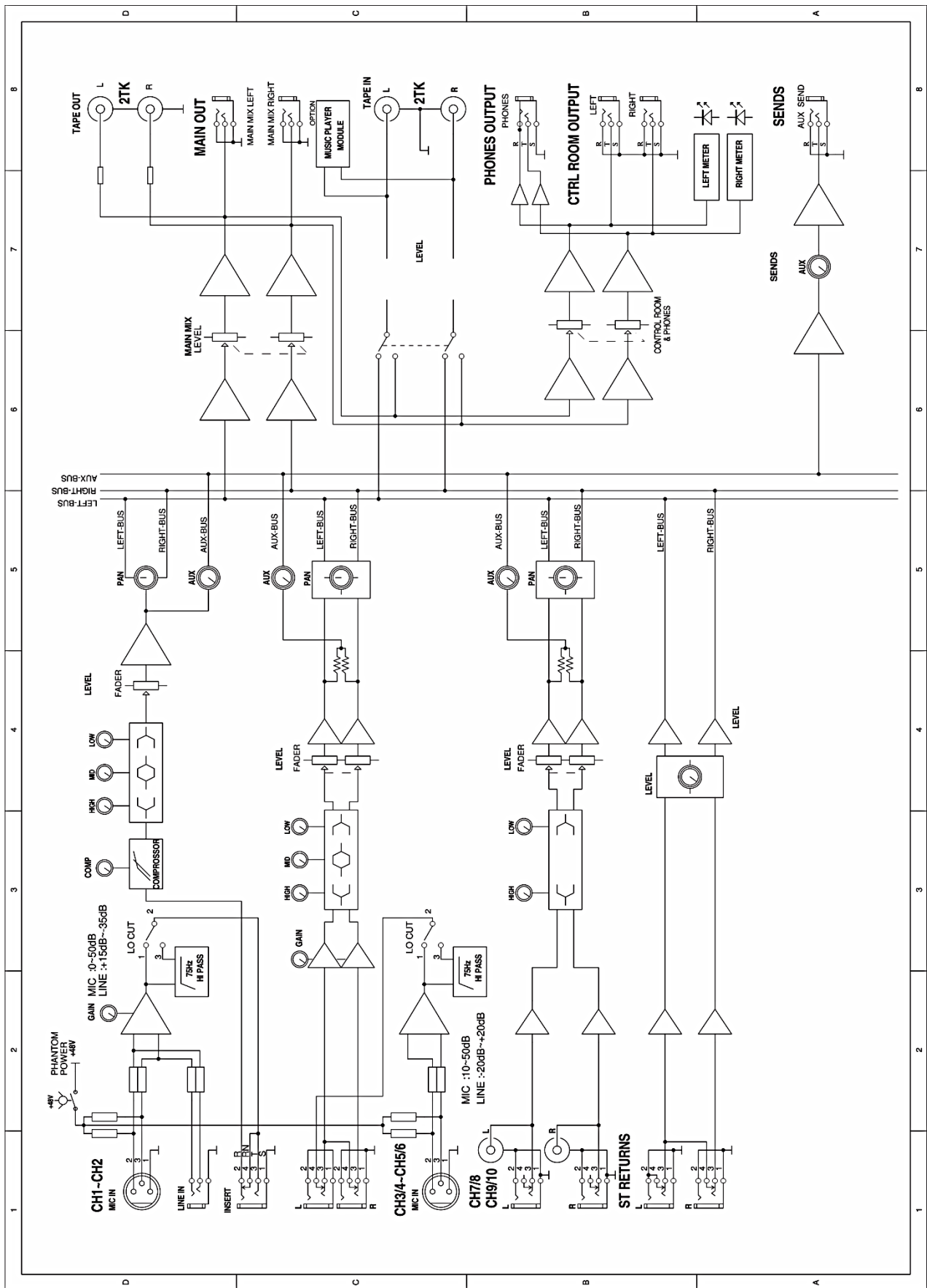

Technical Specifications

MODEL: GIG-104C mixing console

Mono channels

Microphone input XLR balanced
 Frequency response 10Hz to 55KHz, +/-3dB
 Distortion(THD+N) <0.03% at +0dB ,22Hz~22KHz A-weighted
 Gain range 0dB to 50dB
 Max. Input +15 dB
 LOW CUT 100Hz
 SNR <-100dBr A-weighted
 Phantom power +48V with switch control
 Line input 1/4' TRS balanced
 Frequency response 10Hz to 55KHz, +/-3dB
 Distortion(THD+N) <0.03% at +0dB ,22Hz~22KHz A-weighted
 Sensitivity range +15dB~ -35dB

Stereo input channels

Line input 1/4' TRS un-balanced
 Frequency response 10Hz to 55KHz, +/-3dB
 Distortion(THD+N) <0.03% at +0dB ,22Hz~22KHz A-weighted
 Max. Input +22dBu
 SNR <-100dBr A-weighted

Channels EQ

	mono channel	stereo channel
High	+/-15dB@12KHz	+/-15dB@12KHz
Mid	+/-15dB@2.5KHz	
Low	+/-15dB@80Hz	+/-15dB@80Hz

2-TACK IN

TAPE IN RCA jack
 Frequency response 10Hz to 55KHz, +/-3dB
 Distortion(THD+N) <0.03% at +0dB ,22Hz~22KHz A-weighted
 Gain range OFF to 10dB

AUX RETURNS

Input 1/4' TRS un-balanced
 Frequency response 10Hz to 55KHz, +/-3dB
 Distortion(THD+N) <0.03% at +0dB ,22Hz~22KHz A-weighted
 GAIN range OFF TO +10dB
 SNR <-100dBr A-weighted

Impedances

Microphone input 3.6K Ω
 All other input 10K Ω or greater
 Tape out 1K
 All other out 120 Ω

Main mix section

Max. MAIN MIX output +22dBu un-balanced
 AUX range OFF to +10dB
 Fader range OFF to +10dB
 PHONES/CONTROL-ROOM range OFF to +15dB
 Hum & Noise <-80dB@20Hz~22KHz A-weighted 1 channel & MAIN level:0dB, the other :minimum
 Crosstalk <-80dB@0dB 20Hz~22KHz A-weighted MAIN level:0dB, the other :minimum,

Power supply

AC adaptor 230VAC ~50/60Hz 1000mA
 Rated power consumption 17W (all loaded)

Dimensions

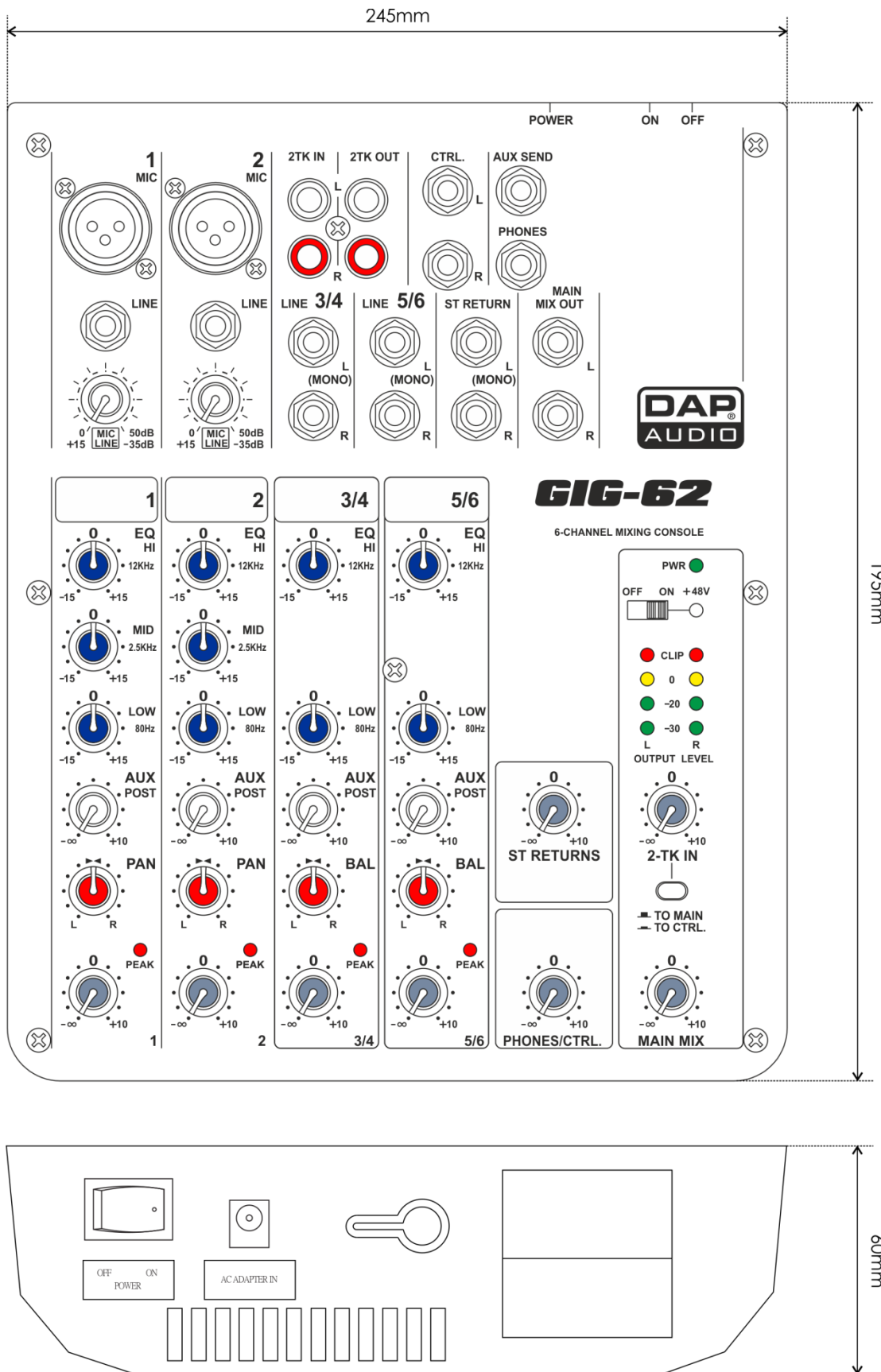



©2013 DAP Audio