

Mechanical specifications

Construction	sturdy aluminium housing.
Paint/Finish	black epoxy powder paint
Rear mounting plate	160x160mm – 6,29x6,29in, included
Barndoor slots	4, to accept a 185x185mm / 7,28x7,28in plate
Safety cable	black, 60cm / 23 5/8in, supplied with the scroller
Front opening dimensions	ø135mm – 5.314in

Electrical specifications

DC power input	24 V DC
Power consumption	11W
Current requirement	0,6 amps (24V DC)

Operational specifications

Gel string capacity	8, 11,16 and 21 frames. At power on the unit automatically detects the number of frames mounted
Gel string movement	step or continuous mode; the scroll speed can be set on the unit or remotely using the optional Speed channel.
Scroll speed	Min. 1,6 sec (head to tail, 21 frames)
Gel string cooling system	Single fan with 5 preset variable speeds or remotely controlled using a dedicated channel
Motor	2 DC servo motors directly fixed to the rollers (NO GEAR BOX)
DMX/Power in	XLR 4-pin male - DMX 512 and 24V DC power
DMX/Power out	XLR 4-pin female - DMX 512 and 24V DC power
Daisy chaining	Up to 6 units per power distribution unit (PDU6)
LED status indicators	Red = power. Green = system, Yellow = signal
DMX channels	min. 1, up to 4 more channels required if remote selection of Reset, Scroll Speed, Fan Speed or Operational Modes are used.
Operational modes	continuous or step, selectable by pressing the UP and DOWN buttons
Head + tail colour filter size	565mm (W) x 156mm (H) – 22,24in (W) x 6,22in (H)
Central frames col. filter size	275mm (W) x 156mm (H) – 10,82in (W) x 6,22in (H)
DMX power/control cable	Not supplied. High quality shielded twist pair type cable with XLR-4 pin connectors are accessories
Net/packed weight	2,2 kg / 2,5 kg - 4,58lb / 5,52lb
Packed volume	0.01m ³ - 0,0353in ³

Accessories

20106260	PDU 6M power distrib. unit for up to 6/8 scrollers. DMX/RDM		
20106020	PDU 1 power distrib. unit for 1 scroller, DMX		
20106024	PDU 24 power distrib. unit for up to 24 scrollers, DMX		
20600002	mounting plate 125x125mm – 4,92x4,92in		
20600003	mounting plate 150 x 150mm - 5,9x5,9in		
20100313	4-leaf barndoor, aluminium		
20620013	21-frame spare gel string, LEE, standard sequence		
20621013	21-frame spare gel string, LEE, special sequence		
20610003	DMX XLR-4pin cable 3m	20610015	DMX XLR-4pin cable 15m
20610005	DMX XLR-4pin cable 5m	20610020	DMX XLR-4pin cable 20m
20610010	DMX XLR-4pin cable 10m	20610025	DMX XLR-4pin cable 25m

* custom mounting plates, gel strings and cables are available on request

standard gel string, 21 LEE colours, pre-loaded and supplied with the scroller

1	130 Clear	12	113 Magenta
2	256 Half Hampshire Frost	13	026 Bright Red
3	152 Pale Gold	14	192 Flesh Pink
4	176 Loving Amber	15	126 Mauve
5	020 Medium Amber	16	115 Peacock Blue
6	104 Deep Amber	17	117 Steel Blue
7	103 Straw	18	089 Moss Green
8	101 Yellow	19	119 Dark Blue
9	179 Chrome Orange	20	181 Congo Blue
10	128 Bright Pink	21	201 Full C.T. Blue
11	048 Rose Purple		

Xpress 13 dmx/rdm

dmx/rdm controllable colour
scroller

part number : 20106013

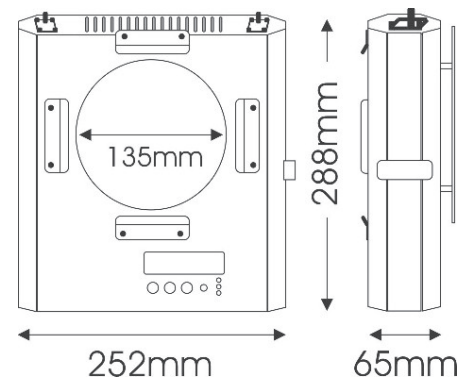

Xpress 13. DMX/RDM controllable colour scroller is ideal for use with LDR 500/650W luminaires - or any with a front aperture up to 135mm (150x150mm/5.9x5.9 in colour frame).

The Xpress 13 is supplied fitted with a 21-colour Lee filter gel string, a 160x160mm (6.29x6.29 in) rear mounting plate and black steel safety bond. Xpress 13 also features 4 front attachments for the optional rotating barndoor accessory.

A large selection of standard and customized rear mounting plates is available on request.



AMLUX srl
Via Belgio, 11/13
46042 Castel Goffredo (MN)
Tel. +39 0376781094
www.amlux.it - info@amlux.it